



MODEL NO	F1 (N)	F2 (N)	F3 (N)	F4 (N)	Fi		AÇI (ANGLE) (± 5°)	AĞIRLIK (WEIGHT) (gr)
					X1 VERİM (YIELD) (F1:Fi)	X2 VERİM (YIELD) (F2:Fi)		
121-3	2500	1250	2800	1400	9:1	4,5:1	71°	460

F1 - F2 : BASKI KUVVETİ (EXERTING FORCE) , F3 - F4 : TUTMA KAPASİTESİ (HOLDING CAPACITY) ,
Fi : UYGULAMA KUVVETİ (APPLIED FORCE)



Ayak Tipi: Yatay, Alçak Tabanlı
Body Mounting Base: Horizontal, Low Base

Ürün özellikleri ;

Yüksekliği otomatik ve kademesiz olarak ayarlanabilen çene sayesinde 40 mm kalınlığa kadar olan iş parçalarını baskı kuvveti değişmeden sıkıştırabilir. Sıkma kuvveti mekanizma üzerinde bulunan ayar vidasından ayarlanabilir.

Features of products ;

The automatic toggle clamp automatically adjusts to the height of the particular work piece.

The infinitely variable jaw height is up to 40 mm for the horizontal toggle clamp while the clamping force remains unchanged.

Using the set screw on the cantilevered joint, the clamping force can be adjusted to your particular requirements

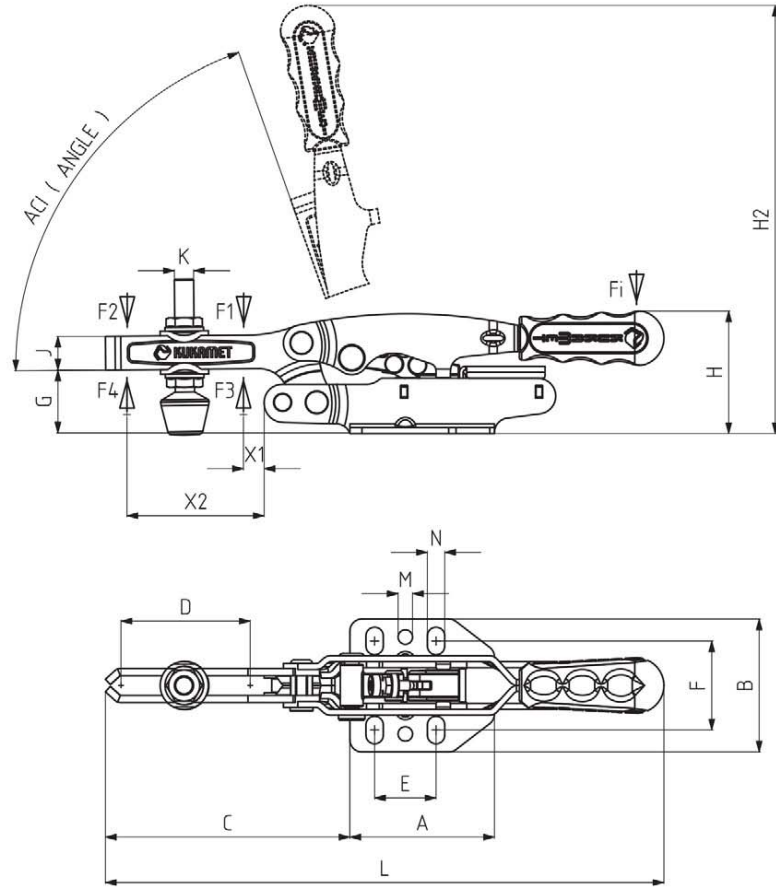
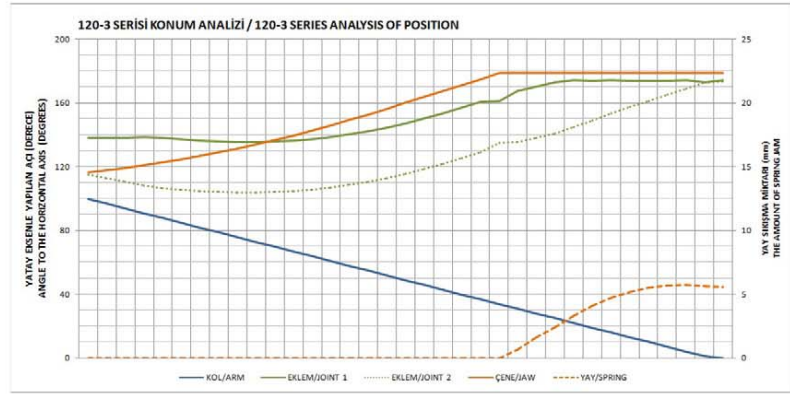

MODEL NO	A	B	C	D	E	F	G	H	H2	J	K	L	M	N	X1	X2
121-3	60	55,5	101,5	50	25,5	32,5 - 41	26,5	51	187	14	M8	232	Ø6	7x11,5	16	50