

532

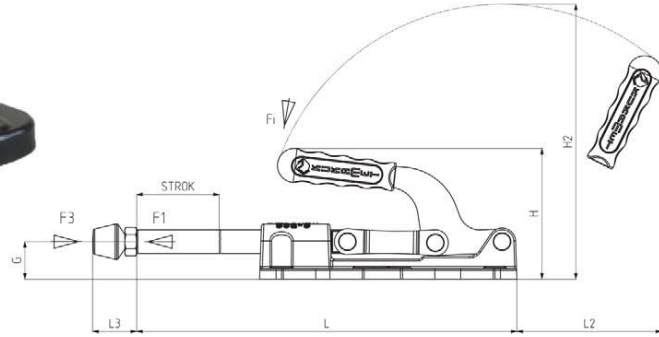

MODEL NO	F1 (N)	F3 (N)	Fi		BASKI VİDASI (SQUEEZE SCREW)	STROK	AĞIRLIK (WEIGHT) (gr)
			VERİM (YIELD) (F1:Fi)				
532-3 (Ø 12)	2500	3700	16:1		M8X50	38	590
532-3 (Ø 14)	2500	4000	16:1		M8X50	38	610
532-4 (Ø 16)	4500	8100	23:1		M10X70	47	1030
532-4 (Ø 18)	4500	8800	23:1		M10X70	47	1060
532-5 (Ø 20)	7500	18450	30:1		M12X80	100	2870

F1 : BASKI KUVVETİ (EXERTING FORCE) , F3 : TUTMA KAPASİTESİ (HOLDING CAPACITY)
Fi : UYGULAMA KUVVETİ (APPLIED FORCE)



Ayak Tipi: Yatay Tabanlı, Döküm Gövdeli
Body Mounting Base: Horizontal, Casting

Ürün özellikleri ;

Ağır iş uygulamalarında kullanıma uygun mukavemetli ürünlerdir.
Gövde mukavemetli GGG-60 döküm malzemeden üretilmiş ve siyah elektro statik toz boya ile boyanmıştır.

Mil, yüksek aşınma direnci ve korozyon direnci için sert krom kaplı malzemeden üretilmiştir.
Mekanizma parçaları çelik malzemeden üretilmiş ve korozyon direnci için galvaniz kaplama yapılmıştır.

Features of product

The products are strength and suitable for heavy duty.

The body made of strength,GGG-60 casting material and painted with black electrostatic powder paint.

The rod made of hard chrome plated material for high wear resistance and corrosion resistance.

The mechanism parts made of steel material and Coated galvanized for corrosion resistance.

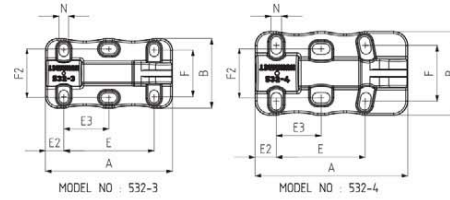
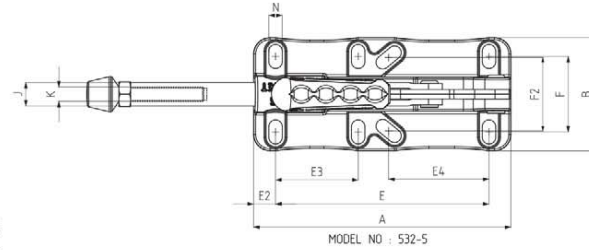

MODEL NO	A	B	C	D	E	E2	E3	E4	F	F2	G	H	H2	J	K	L	L2	L3 Min	L3 Max	M	N
532-3 (Ø 12)	107	59			76,5	15,5	35,5 - 41		36,5 - 42,5	41	17,5	73	127	12	M8	156	81	24	58		8x11
532-3 (Ø 14)	107	59			76,5	15,5	35,5 - 41		36,5 - 42,5	41	17,5	73	127	14	M8	156	81	24	58		8x11
532-4 (Ø 16)	130	71			74,5 - 75,5	18	35 - 41		41,5 - 53	41,5	20,5	86	159	16	M10	188	94	32	81		9x15
532-4 (Ø 18)	130	71			74,5 - 75,5	18	35 - 41		41,5 - 53	41,5	20,5	86	159	18	M10	188	94	32	81		9x15
532-5 (Ø 20)	218	96			180,5	18,5	70	80 - 90	55 - 73	54 - 70,5	31,8	111	234	20	M12	322	122	39	94		11x20

532-5'de baskı ucu dahil değildir./ Squeeze part is not included at 532-5

Dimensions and technical data are subject to change without notice.

-www.kukamet.com.tr-

45