

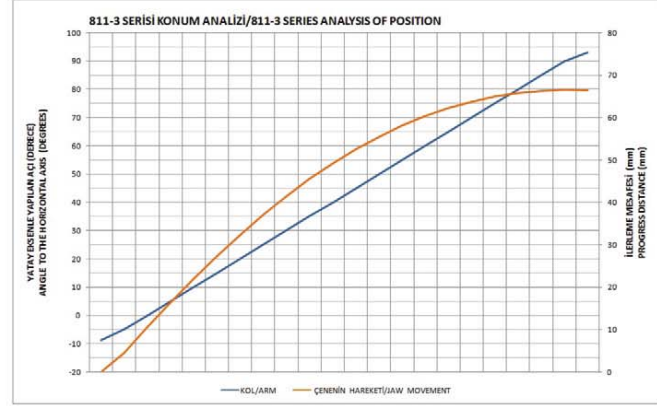

MODEL NO	SİYAH (BLACK)	F1 (N)	F3 (N)	Fi	AĞIRLIK (WEIGHT) (gr)
				VERİM (YIELD) (F1:Fi)	
811-1	B811-.....	1000	2500	27:1	700
811-2	B811-.....	3500	4500	36:1	1060
811-3	B811-.....	4000	6000	38:1	1600

F1 : BASKI KUVVETİ (EXERTING FORCE), F3 : TUTMA KAPASİTESİ (HOLDING CAPACITY),
Fi : UYGULAMA KUVVETİ (APPLIED FORCE)



Ayak Tipi: Yatay Tabanlı
Body Mounting Base: Horizontal

Ürün özellikleri;
Ağır iş uygulamalarında kullanıma uygun mukavemetli ürünlerdir.
Clamp çenesi sıcak dövme çelikten yapılmıştır.
Diğer parçaları çelik malzemeden üretilmiş ve korozyon direnci için galvaniz kaplama yapılmıştır.

Features of product;
The products are strength and suitable for heavy duty.
Clamping jaw made of hot forged steel.
The other parts made of steel material and coated galvanized for corrosion resistance.

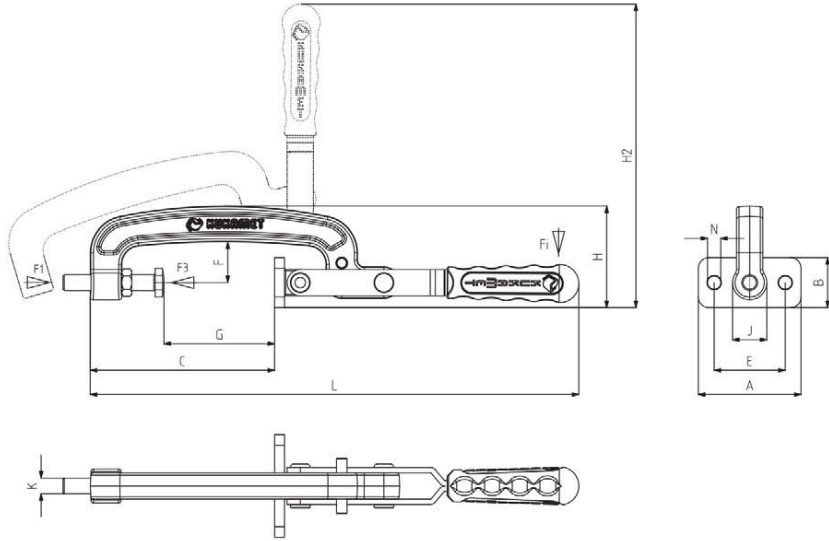

MODEL NO	A	B	C	D	E	F	G Min.	G Max.	H	H2	J	K	L	M	N
811-1	58	38	77		40	24	23	50	60	204	16	8	282		Ø 8
811-2	68	38	110		45	28	46	80	69	217	20	10	330		Ø 8
811-3	78	38	140		54	31	53	100	77	230	26	12	372		Ø 10