

6022



MODEL NO	PİSTON Ø	Strok (mm)	Max. Tutma Uzaklığı (Max. Length of Gripping) (L)	Sıkma Kuvveti (N) (Clamping Force) (N) 5 bar / for 5 bar		Çalışma Basıncı Aralığı (Operation Pressure Range)	Max. Frekans (Max. Frequency)	Ağırlık (Weight) (gr)
				kapalı (closed)	açık (open)			
6022 - 16	16	8	4	24	18	1,5 - 7 bar	180 cycles/min	144
6022 - 20	20	12	6	47	35			255
6022 - 25	25	14	7	75	60			419
6022 - 32	32	16	8,5	100	85			719

L : Tutma Uzaklığı / Length of Gripping (cm) M : Teorik Moment / Theorem Moment (N.cm)

F : Sıkma Kuvveti / Holding Force (N) P : Uygulama Basıncı / Operation Pressure (bar)

Sıkma Kuvvetleri : P = 5 bar basınç ile L = 3 cm tutma uzaklığı durumunda geçerlidir / Clamping forces are valid in case of P = 5 bar pressure with gripping length L = 3 cm



PARALEL TUTUCU

- Silindir çift etkili ve manyetikdir.
- Gövde mukavemetli alüminyumdan üretilmiştir.
- Tutucu çeneler çelikten üretilmiş ve sertleştirilmiştir.
- Piston konumunu izlemek için, gövde üzerinde "T" tip ve "C" tip sensörlere uygun kanallar mevcuttur.
- Tutma eylemi, piston itme konumunda iken gerçekleştiği için daha fazla sıkıştırma kuvveti sağlanır.

PARALLE GRIPPER

- Cylinder is double acting and magnetic.
- The body is made of strength aluminum.
- The gripper jaws made of steel and hardened.
- There are slots on the body, according to T type and C type sensors, for monitoring the position of piston.
- The closing action of the gripper is generated from the cylinder's thrust side, resulting in a higher gripping force.

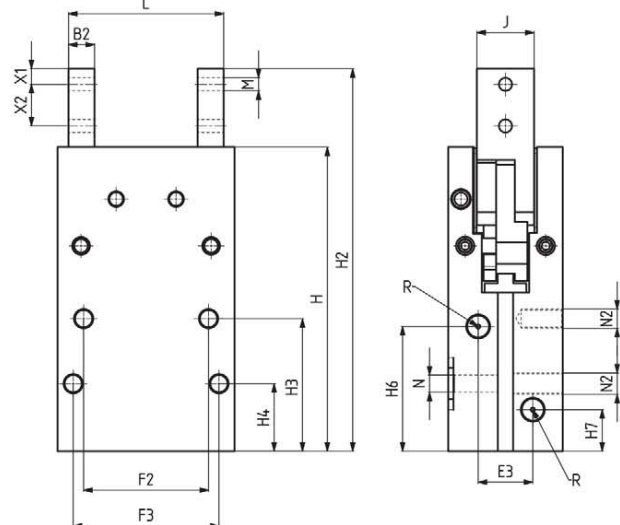
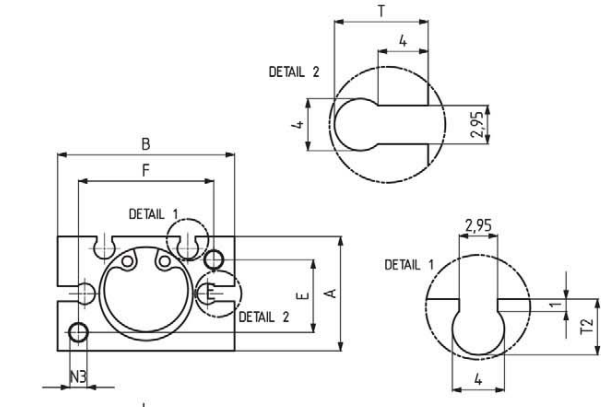
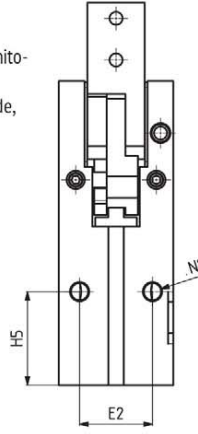
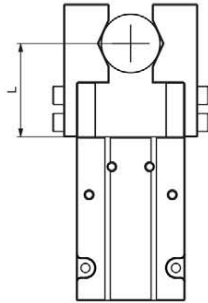

Montaj seçenekleri

* Pnömatik tutucu ergonomik tasarımı sayesinde 4 farklı şekilde montaj yapılabilir.

Mounting options

* Pneumatic gripper can be mounted 4 different way through to ergonomic design.

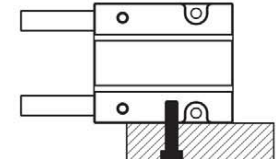
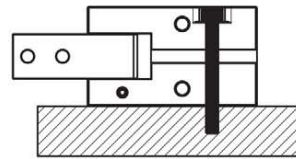
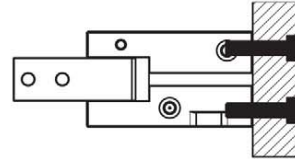
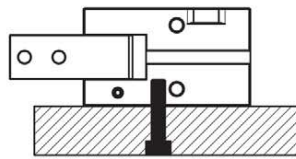

MODEL NO	A	B	B2	E	E2	E3	F	F2	F3	H	H2	H3	H4	H5	H6	H7	J	L Min	L Max	M	N	N2	N3	R	T	T2	X1	X2
6022 - 16	22	34	5	14	14	10,5	26	24	28	58,5	73,5	25,5	13	18	23,5	7	11	25	33	M3	3,3	M4	M4	M5	7	4,3	3	8
6022 - 20	26	45	6	16	16	15	35	30	36	69,5	88	29	13	19	26,5	8	12	32	44	M4	4,2	M5	M5	M5	10	4,3	4	10
6022 - 25	32	52	8	20	20	18	40	36	36	78,5	102,5	28,5	15	21,5	29	8	14	37	51	M5	4,2	M5	M6	M5	11	4,3	5	12
6022 - 32	40	60	10	26	26	24	46	44	50	90,5	120,5	37,5	18	30	34	10,5	18	43	59	M6	5	M6	M6	M5	11	5,5	7	15

Dimensions and technical data are subject to change without notice.

-www.kukamet.com.tr-

79