

**CNC Yatay İşleme Tablası**

CNC Horizontal Clamping Pallet

Referans Nr.	a ±0.02	b	c	d	e	f	g	h ±0.02	(kg)
2490-7540014	75	400	320	14	55	18	160	80	71
2490-7550014	75	500	400	14	75	18	200	100	115
2490-7563014	75	630	500	14	100	18	250	125	188
2490-7540018	75	400	320	18	55	18	160	80	65
2490-7550018	75	500	400	18	75	18	200	100	107
2490-7563018	75	630	500	18	100	18	250	125	178



**Ürün Nr. 2490 Yatay İşleme Tablası "T" Kanallı**

- Malzeme GG 26 DIN normalize edilmiştir.
- Standart bağlama ekipmanlarına uyumludur.
- "T" kanal ölçüsü 14mm - 18mm DIN 650 standartındadır.

**Product Nr. 2490 Horizontal Clamping Pallet with "T" Slot**

- Material is normalized as GG 26 DIN.
- It is in compliance with Standard Coupling Equipment.
- "T" Slot measurement of 14mm - 18mm is in DIN 650 Standard.

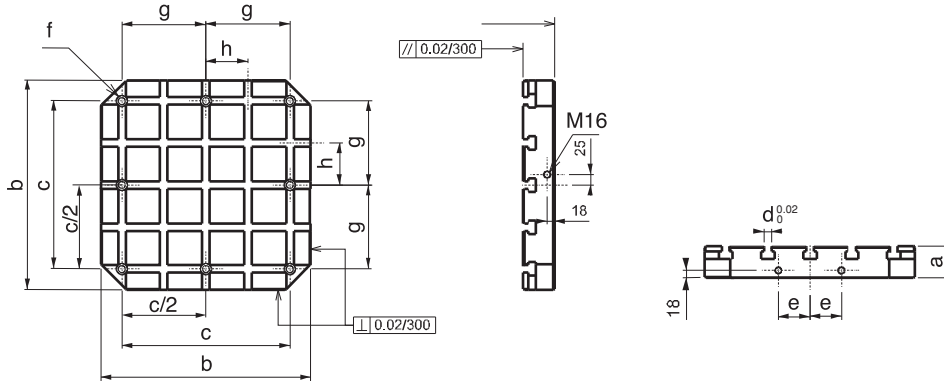

Referans Nr.	a ±0.02	b	c	d	e	m	(kg)
2510-7540012	75	400	320	55	25	M12	80
2510-7550012	75	500	400	75	25	M12	127
2510-7563012	75	630	500	100	40	M12	204
2510-7540016	75	400	320	55	25	M16	79
2510-7550016	75	500	400	75	25	M16	125
2510-7563016	75	630	500	100	40	M16	200

**CNC Yatay İşleme Tablası**

CNC Horizontal Clamping Pallet



Referans Nr.	a ±0.02	b	c	d	e	m	(kg)
2520-7540012	75	400	320	55	25	M12	80
2520-7550012	75	500	400	75	25	M12	127
2520-7563012	75	630	500	100	40	M12	204
2520-7540016	75	400	320	55	25	M16	79
2520-7550016	75	500	400	75	25	M16	125
2520-7563016	75	630	500	100	40	M16	200

Gövdeye dişli  
Referans Nr. 2510  
Threaded body  
Reference No. 2510

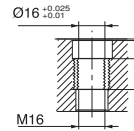
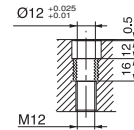

**Ürün Nr. 2510 Yatay İşleme Tablası Delikli**

- Malzeme GG 26 DIN normalize edilmiştir.
- Standart bağlama ekipmanlarına uyumludur.
- Yüzeyinde M12 - M16 diş merkez aralığı 50 ± 0.02
- Çelik burçlu dişleri sertleştirilmiştir.

**Product Nr. 2510 Horizontal Clamping Pallet with Grid Holes**

- Material is normalized as GG 26 DIN.
- It is in compliance with Standard Coupling Equipment.
- M12 - M16 thread gap on it's surface is 50 ± 0.02.
- It's steel bush threads are hardened.

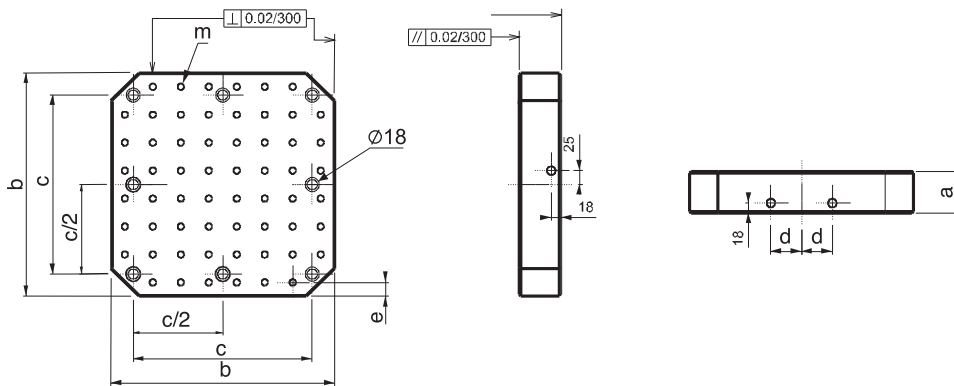

Çelik burçlu  
Referans Nr. 2520

Steel bush  
Reference No. 2520