

Referans Nr.	Sıkma Yüksekliği Clamping Height				Sıkma Torku Clamping Stroke	L2	L3	L1	L4	W	L	H4	B	Dp
	Finiş Yüzey Temas Finished Surface Contact		Kaba Yüzey Temas Rough Surface Contact											
	Min.	Max.	Min.	Max.										
1479-0618	21.8 (21.8-24.8)	23.8 (23.8-26.8)	21.4 (21.4-24.4)	23.4 (23.4-26.4)	3	22	6	26	11.5	36	18	6	4.3	27
1479-0823	30.3 (30.3-34.3)	32.3 (32.3-36.3)	31.2 (31.2-35.2)	33.2 (33.2-37.2)	4	30	8	35	15.3	45	23	8	5.3	34
1479-1030	30.5 (30.5-34.5)	37 (37-41)	31.5 (31.5-35.5)	38 (38-42)	4	37	8	45	20.7	65	30	12	8.4	48
1479-1240	34.5 (34.5-39.5)	44 (44-49)	37 (37-42)	46.5 (46.5-51.5)	5	45	8	55	25.4	85	40	15	10.5	64

Referans Nr.	H	D	W1	W2	H2	H1	M1	H3	W3	M	Sıkma Kuvveti Clamping Force Kgf	izin Verilen Tork Allowable Screw Torque (N-m)	 (g)
1479-0618	56.5	18	8	4.3	10	29	M4	22.8	10	M6	230	6	94
1479-0823	73.5	23	10	5.3	14	39	M5	28.5	13	M8	360	10.5	210
1479-1030	91	30	16	8.4	18	48	M8	45.5	17	M10	600	30	515
1479-1240	114	40	20	10.4	22	58	M10	57	19	M12	750	45	1100

Ürün Nr. 1479 Dönmeli Üstten Bağlama

- Gövde**
- Malzeme: 42 CrMo 4 DIN
 - Sertlik: 38-42 HRC
 - Siyah Kaplama

- Sıkma Mili**
- Malzeme: Ck45 DIN
 - Siyah Kaplama

Product Nr. 1479 Swing Clamps For Torque Control

- Body**
- Material: 42 CrMo 4 DIN
 - Hardness: 38-42 HRC
 - Black coated

- Clamping Spindle**
- Material: Ck45 DIN
 - Black coated

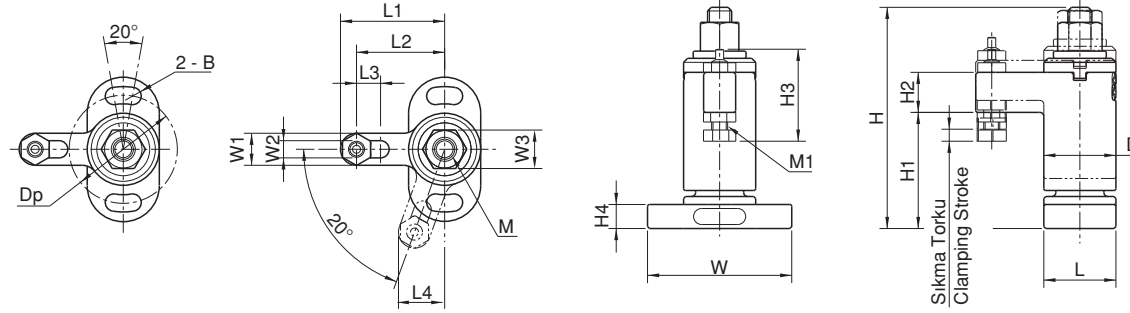

- Not**
- Bağlama işlemini tork anahtarı ile yapın.

- Note**
- Do not use a power tool (impact wrench etc.) to turn the flange nut, for damage prevention.

Kullanım Şekli / How To Use

