

E Wind Mill

WFSP(M) (Düz tip)

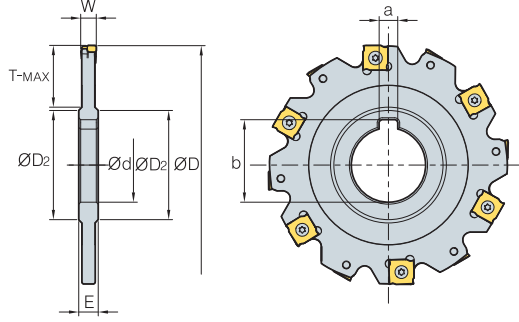

•AR: -2°
•RR: -12°

(mm)

Kod	ØD	W	T-Maks	ØD ₂	Ød	a	b	E	Kesici uç	Vida	Anahtar	
WFSP (WFSBM) 080-T04	8	80	4	20	40	25.4 (27)	6.35 (7)	28 (29.8)	8	SNHT11023R/L-WX	PTMA03503	TW09S
080-T05	8	80	5	20	40	25.4 (27)	6.35 (7)	28 (29.8)	8	SNHT1103R/L-WX	PTMA03504	TW09S
080-T06	8	80	6	20	40	25.4 (27)	6.35 (7)	28 (29.8)	8	SNHT12035R/L-WX	PTMA04045F	TW15S
100-T04	10	100	4	24	47	31.75 (32)	7.92 (8)	35.2 (34.8)	8	SNHT11023R/L-WX	PTMA03503	TW09S
100-T05	10	100	5	24	47	31.75 (32)	7.92 (8)	35.2 (34.8)	8	SNHT1103R/L-WX	PTMA03504	TW09S
100-T06	10	100	6	24	47	31.75 (32)	7.92 (8)	35.2 (34.8)	8	SNHT12035R/L-WX	PTMA04045F	TW15S
100-T07	10	100	7	24	47	31.75 (32)	7.92 (8)	35.2 (34.8)	10	SNHT1204R/L-WX	PTMA0405F	TW15S
100-T08	10	100	8	24	47	31.75 (32)	7.92 (8)	35.2 (34.8)	10	SNHT12045R/L-WX	PTMA0406F	TW15S
100-T09	10	100	9	24	47	31.75 (32)	7.92 (8)	35.2 (34.8)	12	SNHT1205R/L-WX	PTMA0407F	TW15S
100-T10	10	100	10	24	47	31.75 (32)	7.92 (8)	35.2 (34.8)	12	SNHT12054R/L-WX	PTMA0408F	TW15S
125-T04	12	125	4	32	56	38.1 (40)	9.52 (10)	42.3 (43.5)	8	SNHT11023R/L-WX	PTMA03503	TW09S
125-T05	12	125	5	32	56	38.1 (40)	9.52 (10)	42.3 (43.5)	8	SNHT1103R/L-WX	PTMA03504	TW09S
125-T06	12	125	6	32	56	38.1 (40)	9.52 (10)	42.3 (43.5)	8	SNHT12035R/L-WX	PTMA04045F	TW15S
125-T07	12	125	7	32	56	38.1 (40)	9.52 (10)	42.3 (43.5)	10	SNHT1204R/L-WX	PTMA0405F	TW15S
125-T08	12	125	8	32	56	38.1 (40)	9.52 (10)	42.3 (43.5)	10	SNHT12045R/L-WX	PTMA0406F	TW15S
125-T09	12	125	9	32	56	38.1 (40)	9.52 (10)	42.3 (43.5)	12	SNHT1205R/L-WX	PTMA0407F	TW15S
125-T10	12	125	10	32	56	38.1 (40)	9.52 (10)	42.3 (43.5)	12	SNHT12054R/L-WX	PTMA0408F	TW15S
160-T04	16	160	4	45	66	38.1 (40)	9.52 (10)	42.3 (43.5)	8	SNHT11023R/L-WX	PTMA03503	TW09S
160-T05	16	160	5	45	66	38.1 (40)	9.52 (10)	42.3 (43.5)	8	SNHT1103R/L-WX	PTMA03504	TW09S
160-T06	16	160	6	45	66	38.1 (40)	9.52 (10)	42.3 (43.5)	8	SNHT12035R/L-WX	PTMA04045F	TW15S
160-T07	16	160	7	45	66	38.1 (40)	9.52 (10)	42.3 (43.5)	10	SNHT1204R/L-WX	PTMA0405F	TW15S
160-T08	16	160	8	45	66	38.1 (40)	9.52 (10)	42.3 (43.5)	10	SNHT12045R/L-WX	PTMA0406F	TW15S
160-T09	16	160	9	45	66	38.1 (40)	9.52 (10)	42.3 (43.5)	12	SNHT1205R/L-WX	PTMA0407F	TW15S
160-T10	16	160	10	45	66	38.1 (40)	9.52 (10)	42.3 (43.5)	12	SNHT12054R/L-WX	PTMA0408F	TW15S
160-T11	16	160	11	45	66	38.1 (40)	9.52 (10)	42.3 (43.5)	14	SNHT1206R/L-WX	PTKA0409F	TW15S
160-T12	16	160	12	45	66	38.1 (40)	9.52 (10)	42.3 (43.5)	14	SNHT12065R/L-WX	PTKA0410F	TW15S
160-T13	16	160	13	45	66	38.1 (40)	9.52 (10)	42.3 (43.5)	16	SNHT1207R/L-WX	PTKA0411F	TW15S
160-T14	16	160	14	45	66	38.1 (40)	9.52 (10)	42.3 (43.5)	16	SNHT12075R/L-WX	PTKA0412F	TW15S
200-T06	18	200	6	60	70	50.8 (50)	12.7 (12)	55.8 (53.5)	8	SNHT12035R/L-WX	PTMA04045F	TW15S
200-T07	18	200	7	60	70	50.8 (50)	12.7 (12)	55.8 (53.5)	10	SNHT1204R/L-WX	PTMA0405F	TW15S
200-T08	18	200	8	60	70	50.8 (50)	12.7 (12)	55.8 (53.5)	10	SNHT12045R/L-WX	PTMA0406F	TW15S
200-T09	18	200	9	60	70	50.8 (50)	12.7 (12)	55.8 (53.5)	12	SNHT1205R/L-WX	PTMA0407F	TW15S
200-T10	18	200	10	60	70	50.8 (50)	12.7 (12)	55.8 (53.5)	12	SNHT12054R/L-WX	PTMA0408F	TW15S
200-T11	18	200	11	60	70	50.8 (50)	12.7 (12)	55.8 (53.5)	14	SNHT1206R/L-WX	PTKA0409F	TW15S
200-T12	18	200	12	60	70	50.8 (50)	12.7 (12)	55.8 (53.5)	14	SNHT12065R/L-WX	PTKA0410F	TW15S
200-T13	18	200	13	60	70	50.8 (50)	12.7 (12)	55.8 (53.5)	16	SNHT1207R/L-WX	PTKA0411F	TW15S
200-T14	18	200	14	60	70	50.8 (50)	12.7 (12)	55.8 (53.5)	16	SNHT12075R/L-WX	PTKA0412F	TW15S
250-T06	20	250	6	88	70	50.8 (50)	12.7 (12)	55.8 (53.5)	8	SNHT12035R/L-WX	PTMA04045F	TW15S
250-T07	20	250	7	88	70	50.8 (50)	12.7 (12)	55.8 (53.5)	10	SNHT1204R/L-WX	PTMA0405F	TW15S
250-T08	20	250	8	88	70	50.8 (50)	12.7 (12)	55.8 (53.5)	10	SNHT12045R/L-WX	PTMA0406F	TW15S
250-T09	20	250	9	88	70	50.8 (50)	12.7 (12)	55.8 (53.5)	12	SNHT1205R/L-WX	PTMA0407F	TW15S
250-T10	20	250	10	88	70	50.8 (50)	12.7 (12)	55.8 (53.5)	12	SNHT12054R/L-WX	PTMA0408F	TW15S
250-T11	20	250	11	88	70	50.8 (50)	12.7 (12)	55.8 (53.5)	14	SNHT1206R/L-WX	PTKA0409F	TW15S
250-T12	20	250	12	88	70	50.8 (50)	12.7 (12)	55.8 (53.5)	14	SNHT12065R/L-WX	PTKA0410F	TW15S
250-T13	20	250	13	88	70	50.8 (50)	12.7 (12)	55.8 (53.5)	16	SNHT1207R/L-WX	PTKA0411F	TW15S
250-T14	20	250	14	88	70	50.8 (50)	12.7 (12)	55.8 (53.5)	16	SNHT12075R/L-WX	PTKA0412F	TW15S

()Metrik Ölçü Kullanılabilir Kesici Uçlar E23



E Frezeleme

356